

Hood S4001 wall



Hoods

Code: 2440 091

90 cm



DETAILS

Material AISI 304 stainless steel

Texture Brushed in line

Chimney height 630 - 1050 mm

Energy class A+

Product details Telescopic chimney

Grease filters 2 grease filters

Operation Suction hood (filtering mode with optional carbon filters)

Air exhaust hole \varnothing 120/150 mm

Lighting LED lighting: 6 x 1W (5.600 kelvin)

Air flow rate 700mc/h

Motor power 160W

Hood type Wall-mounted suction hood

Type of commands Minimal electronic controls

Suction speed 4 operating speeds

Notes: Fume exhaust ducts must have an internal diameter not lower than 120 mm

FEATURES

high performance Foster hoods motors have a high suction capacity. Their refined design hides a powerful appliance with professional features.

Perimetric aspiration The perimeter suction is a feature common to many Foster hoods. The filters are hidden by steel- or crystal plates and the suction occurs along their perimeter. This has aesthetic advantages but also functional ones: the cleaning is easier, the suction power and noise-level are improved. The depression which occurs in the perimeter area facilitates in fact the suction of the particles composing the fumes.

Brushless motor State-of-the-art Brushless motors allow high air flow rates while maintaining a low energy consumption. Furthermore, they have an almost never-ending duration.

Led lighting Particular attention to energy saving with LED lighting systems. They assure a 10 times lower consumption and a 10 times longer duration. Our LED lights are designed to create an adequate comfort and safety in the cooking area.

Auto delayed shutdown All the models with electronic interface can be programmed to turn off the suction at a postponed moment, so as to prolong the aeration of the room even after the cooking has been completed.

TECHNICAL DATA

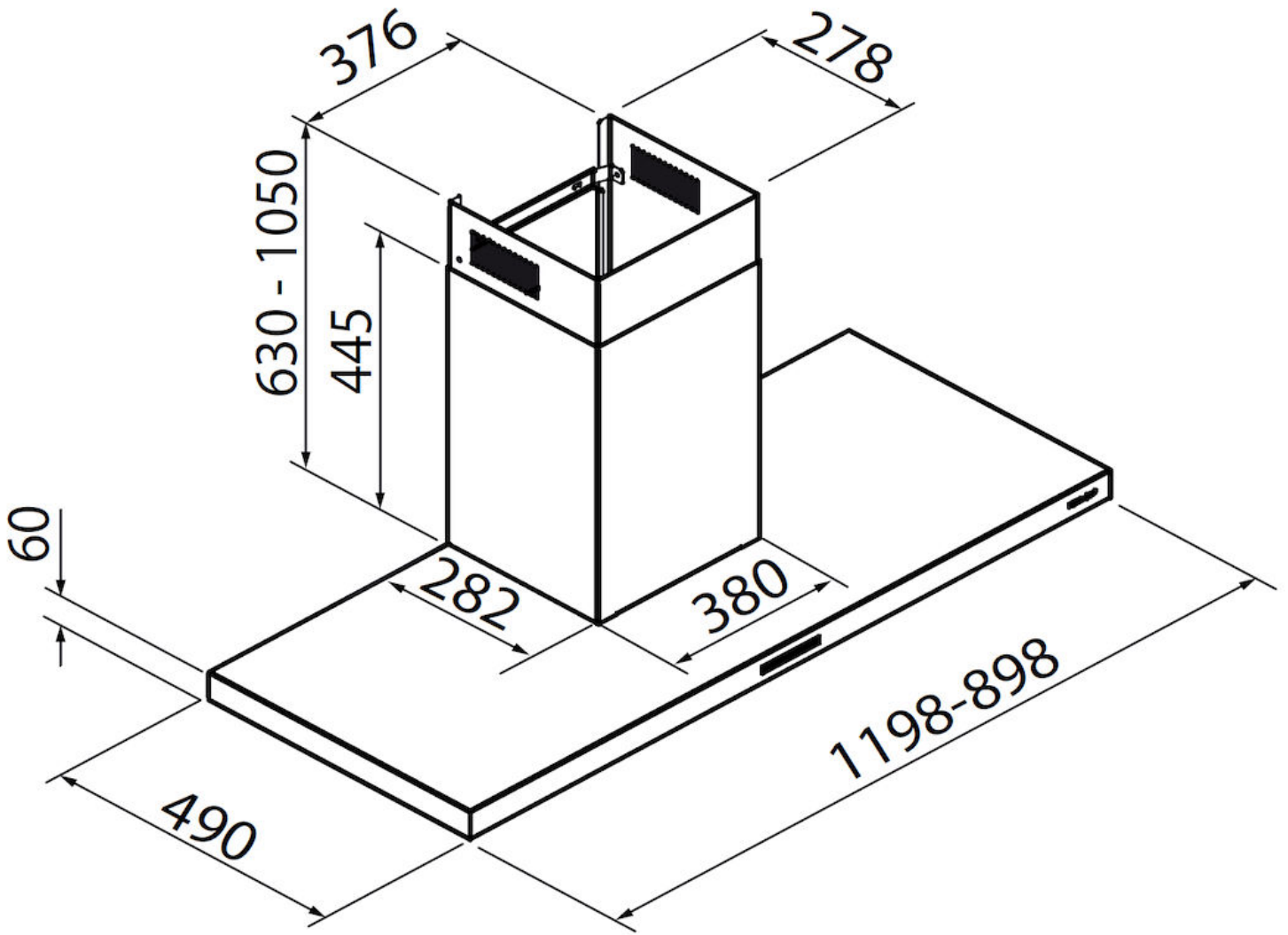

GALLERY



OPTIONAL ACCESSORIES

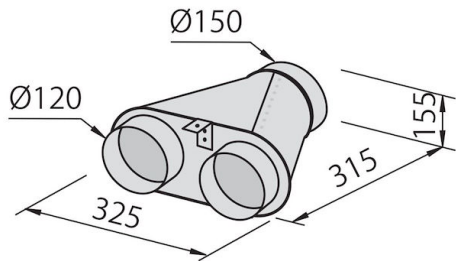

Collector for 2 pipes
2523 000

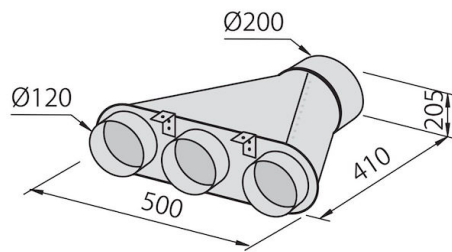

Collector for 3 pipes
2524 000

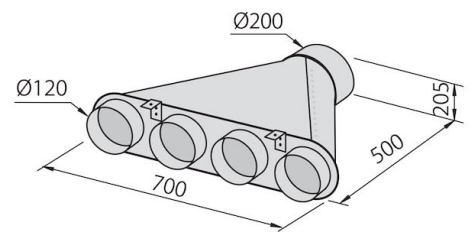

Collector for 4 pipes
2525 000



Flexible silencing canalization
9700 602



Flexible silencing canalization
9700 603



Long Life carbon filter
9700 001